



# SPACE-RAY®

## SUH-S Warm Air Unit

### Indirect Gas Fired Unit Heater

- Energy saving – up to 15% vs conventional unit heaters
- Small, compact design
- Light weight
- Variable air distribution
- Modulating premix burner and fan
- Stainless Steel heat exchanger as standard
- Simple to install

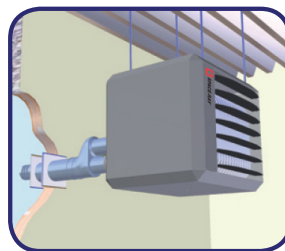
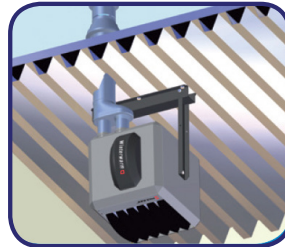

The Space-Ray SUH-S: efficiency, energy saving and total comfort control through unique design characteristics. An indirect gas fired unit heater with innovative burner and heat exchanger combination, provided with the latest control technology.

The compact measurements and the high level of comfort make the SUH-S suitable for many applications in all environments such as factories, industrial units, distribution centres / warehouses, garages, showrooms, retail stores, sports centres and even in restaurants

*Horizontal or vertical air distribution*

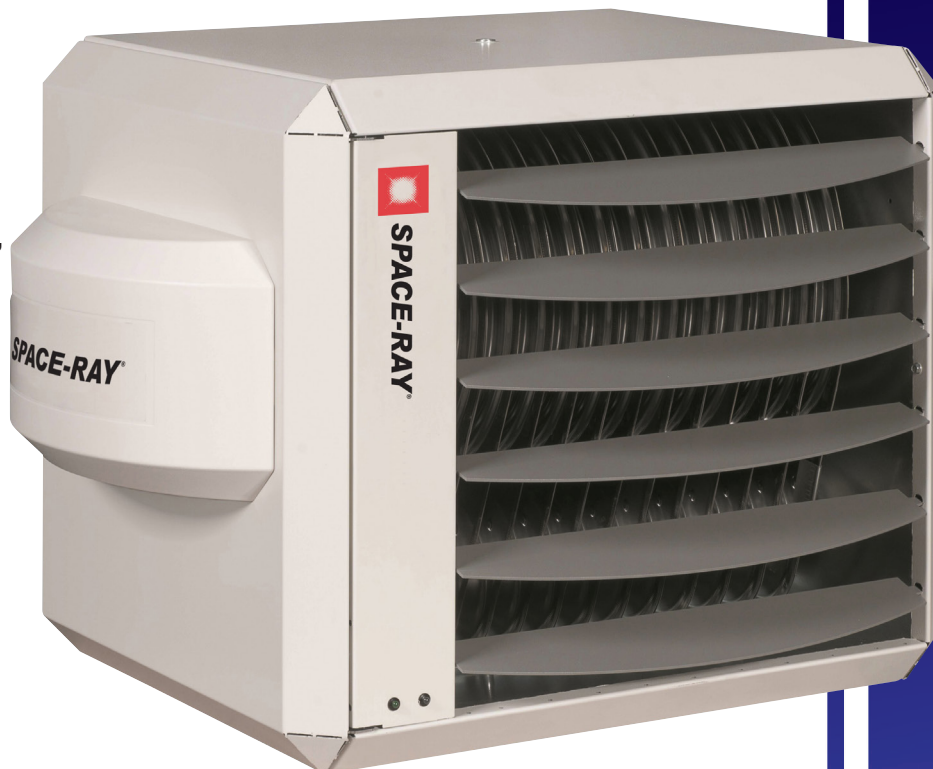
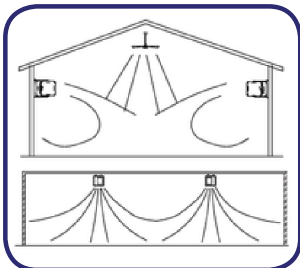

[www.spaceray.co.uk](http://www.spaceray.co.uk)

[www.outdoorheating.spaceray.co.uk](http://www.outdoorheating.spaceray.co.uk)

# SPACE-RAY®

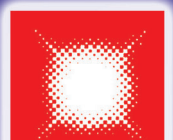

# Heating Systems

### Technical Specifications

DESCRIPTION	Unit	SUH-S10	SUH-S20	SUH-S30	SUH-S40	SUH-S50	SUH-S60
Nominal heat input max.	KW	14.0	22.8	32.0	44.0	55.0	66.0
Nominal heat input min.	KW	9.0	14.8	20.5	26.4	33.0	39.6
Nominal heat output max.	KW	12.8	20.8	29.2	40.2	49.9	60.5
Nominal heat output min.	KW	8.3	13.8	19.1	24.4	30.8	37.0
Air output max.	m3/h	1150	2070	2600	4370	5150	6300
Throw horizontal max.	m	12	16	23	26	28	30
Throw vertical max.	m	5	5	6	7	8	11
Gas connection	G	½"	½"	½"	¾"	¾"	¾"
Supply pressure G20 (H)	mbar	20	20	20	20	20	20
Max. Gas consumption G20 (H)	m3/h	1.5	2.4	3.4	4.7	5.8	7.0
Max. Gas consumption G31	kg/hr	1.1	1.8	2.5	3.5	4.4	5.3
Electrical supply	V	230	230	230	230	230	230
Power consumption	W	250	250	250	450	450	600
Noise level (4m. in front of unit)	dB(A)	42	45	45	46	47	49
Minimum suspension height (horizontal air distribution)	m	1.7	1.7	1.7	2.7	2.7	2.7
Minimum suspension height (vertical air distribution)	m	4	4	4	5	6	6
Weight	kg	36	37	38	78	80	82
Dimensions flue terminal	mm	80	80	80	100	100	100
Max. lenght flue terminal (without elbows)	m	8	8	8	8	8	8

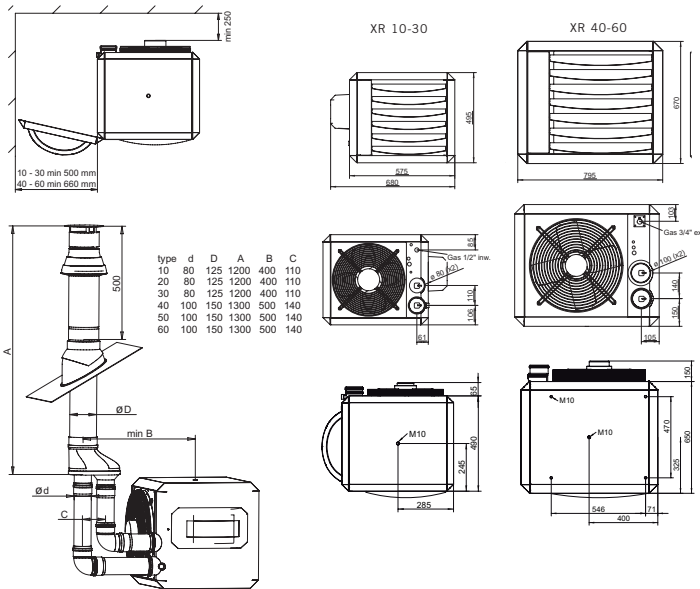

FEATURES	MultiTherm S	MultiTherm C
7 day program		✓
10 different on/off programs		✓
Manual override		✓
Summer/winter time		✓
Modulates the heater according to the room temperature	✓	✓
Summer ventilation	✓	✓
Compensation wall influence	✓	✓
Keyboard locking		✓
Frost protection	✓	✓
Failure diagnosis and reset per unit air heater	✓	✓
Wired in twisted pair screened cable	✓	✓
Controls 1-8 heaters	✓	✓

For more information contact:

Gas Fired Products (UK) Ltd, Chapel Lane, Claydon, Ipswich, Suffolk IP6 0JL UK  
 Telephone: (01473) 830551 Fax: (01473) 832055 Email: info@spaceray.co.uk Website: www.spaceray.co.uk

*We reserve the right to alter specifications without prior notice.*